

PRYMA

IP67 BOXES FOR INDUSTRIAL SOCKETS

Description: IP67 SURFACE BOX 1x9 MOD. (TW). N&E BARS

Reference:
178M/RR

Characteristics:

Product type:	Boxes for industrial sockets with neutral and earth bars
Exterior dimensions (Height x Width x Depth):	369x222x130 mm
Dimensions of the flush-fit gap (HxWxD):	-
Number of modules:	1x9 DIN rail
Installation:	Surface
Color:	Grey RAL 7035
Window:	Transparent tinted window
Weight (Kg):	1,46
Cable entry:	-
Components:	-
Materials:	Halogen-free plastic materials. Frame and base: ABS. Transparent window: UV protection polycarbonate

Technical data:

Degree of protection:	IP67
Resistance to impact:	IK08
Glow wire resistance:	650 °C
Ball pressure test:	70 °C
Ambient temperature range:	-25 °C / +40 °C
Maximum operating voltage:	1000 V AC / 1500 V DC
Double insulation:	Class II

Certificates and standards:

Directive:	2014/35/EU
Standards:	UNE-EN 62208 and UNE-EN 61439-1 (as applicable)
Certificates:	



Codes:

EAN:	8431044101026
Customs tariff number:	85.38.10.00
ETIM 6.0:	EC000379

PRYMA

IP67 BOXES FOR INDUSTRIAL SOCKETS

Description: IP67 SURFACE BOX 1x9 MOD. (TW). N&E BARS

Reference: 178M/RR

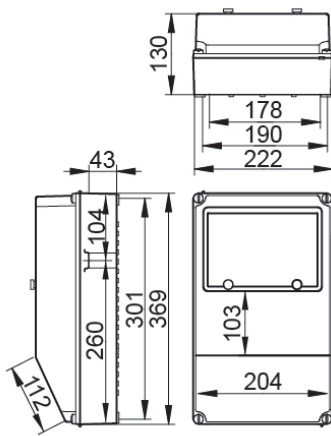

Detailed drawing:

 <http://www.ide.es/downloads/planos/pdf/178MRR.pdf>

 <http://www.ide.es/downloads/planos/dxf/178MRR.dxf>

 <http://www.ide.es/downloads/planos/stp/178MRR.stp>

Exterior dimensions (Height x Width x Depth):

369x222x130 mm

Dimensions of the flush-fit gap (Height x Width x Depth):

-

Sustainability:

RoHS - REACH

Supply:

Supplied in individual cardboard packaging. When several items are sent together, they are bundled together with transparent film.

Packaging units: 5

Product end of life:

It does not require specific recycling operations.

Recommended applications:

Industrial and outdoor environments. Industrial sites, docks, swimming pools, garages, anywhere that requires a high degree of protection against dust, splashes and impacts.